



 POLITECNICO DI MILANO

Fault Tree & Event Tree Analysis

Exercise lesson

Ibrahim Ahmed

ibrahim.ahmed@polimi.it



March, 2026



1. Manually solving the exercises (FTA/ETA)
2. Implementation of the computer programming (R programming language) to solve the same exercises

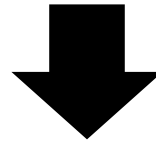

**Requires installations of R and Rstudio
(see slides 21 to 32 for guidelines)**

Manually solving the exercises (FTA/ETA)

Fault Tree Analysis (FTA)



Exercise 1: Simple Systems

- Construct the fault tree for the failure of the systems in the Figure.
- Write the systems structure functions.
- Obtain their minimal cut sets.

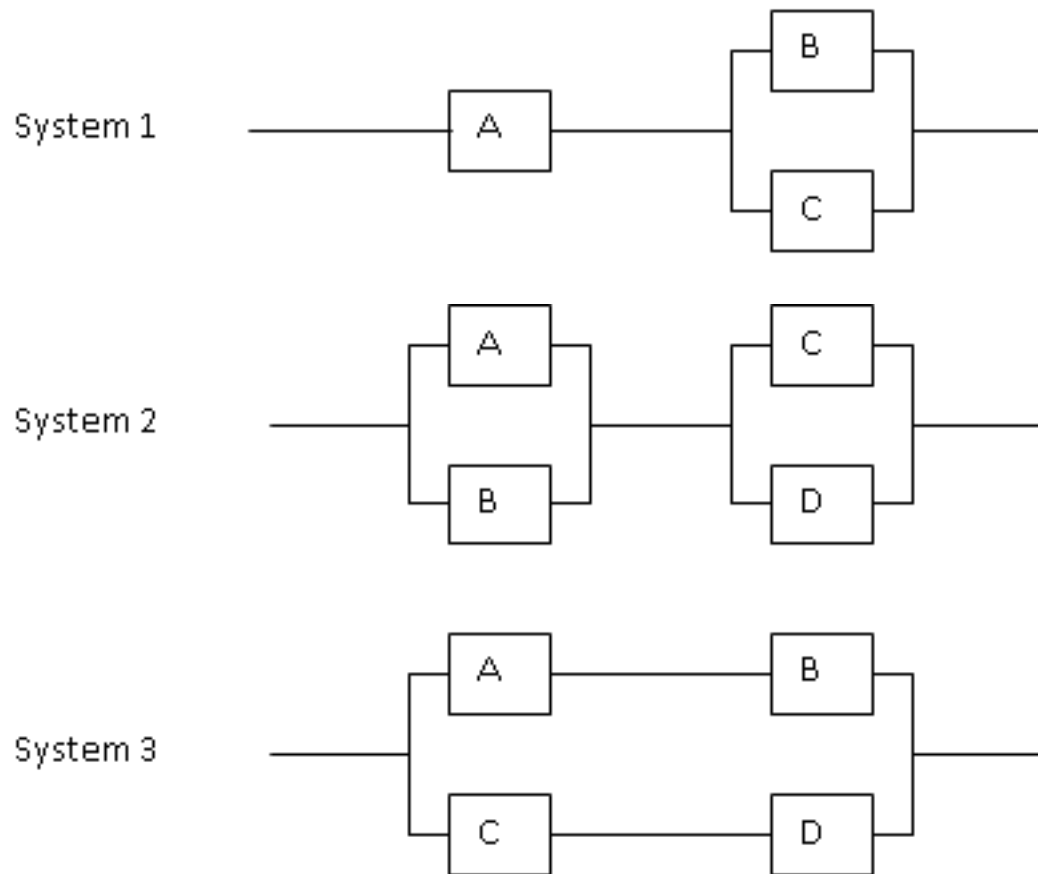



Exercise 2: Network System

Consider the network system below, all components have equal failure probability $p = 5 \cdot 10^{-2}$. The system fails when there is no connection between the source and terminal nodes.

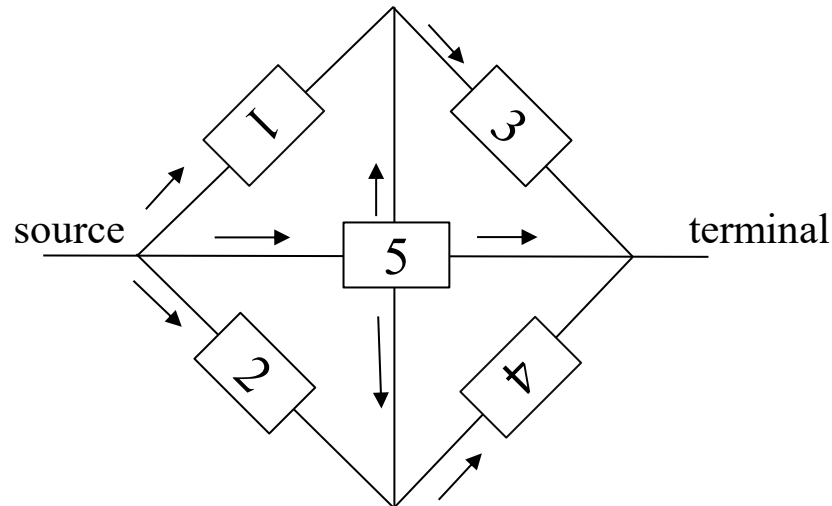

You are asked to:

1. Build the fault tree for the failure of the network system.
2. Identify the minimal cut sets of the network system.
3. Evaluate system unreliability from the minimal cut sets found in question 2.

Exercise 3: Reliability Block Diagram

Consider the Reliability Block Diagram in the Figure.

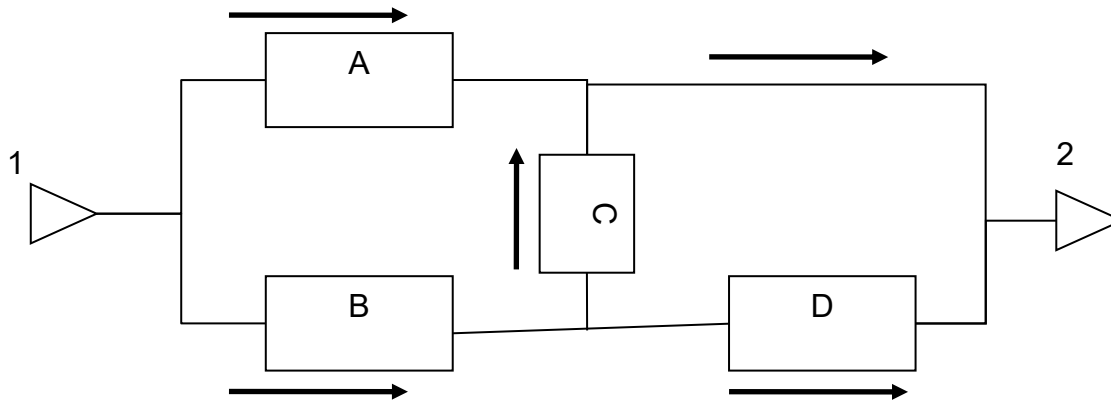

You are asked to:

1. Build the Fault Tree corresponding to the top event: 'no flow from 1 to 2'.
2. Find the minimal cut sets.
3. Compute the system unavailability, given that the unavailability of each component is $U=0.01$.



Exercise 4: Unavailability

A system is successful, if at least two of five nominally identical elements are "up". The probability that one element is "down" is denoted by q .

You are asked to:

1. Find the minimal cut sets (mcs).
2. Using these mcs derive an exact expression for the system unavailability, i.e., the probability that the system is "down".
3. Find the system unavailability using binomial distribution and compare with the result of part 2.
4. How would parts 1., 2. and 3. be affected (i.e. would they still be applicable?), if the elements were not nominally identical (i.e. different probabilities $q_i, i = 1, 2, 3, 4, 5$)? Simply give arguments without carrying out any calculations.



Exercise 5: Electrical generating system

An electrical generating system is shown in the figure below in block diagram form. Only the major components are to be considered: the engines E_1 , E_2 , and the generators G_1 , G_2 , G_3 . Each generator is rated at 30 KVA. The system is required to supply at least 60KVA.

1. Draw a fault tree for the failure of the system to satisfy the required demand.
2. Find the minimal cut sets.
3. Estimate the unreliability of the system for one month (720 h) operation given that the failure rate for each engine is $5 \cdot 10^{-6} \text{ h}^{-1}$ and for each generator 10^{-5} h^{-1} (assume failures of components obey exponential distribution)

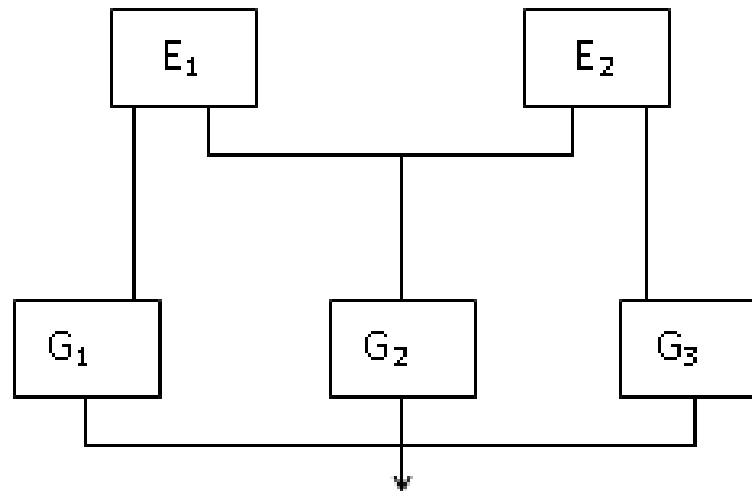



Exercise 6: Domestic Hot Water System

In the domestic hot water system in the Figure, the control of the temperature is achieved by the controller opening and closing the main gas valve when the water temperature goes outside the preset limits

$$T_{\min} = 140F, T_{\max} = 180F.$$

1. Formulate a list of undesired safety and reliability events
2. Construct the fault tree for the top event rupture of water tank assuming only the following primary failure events:

- 1: basic tank failure
- 2: relief valve jammed closed
- 3: gas valve fails jammed open
- 4: controller fails to close gas valve
- 5: basic failure of temperature Monitor

3. Find the minimal cut sets;
4. Assume primary failure event probabilities equal to 0.1 and compute the probability of the top event working through the fault tree;
5. Compute the probability of the top event from the minimal cut sets found in 3.

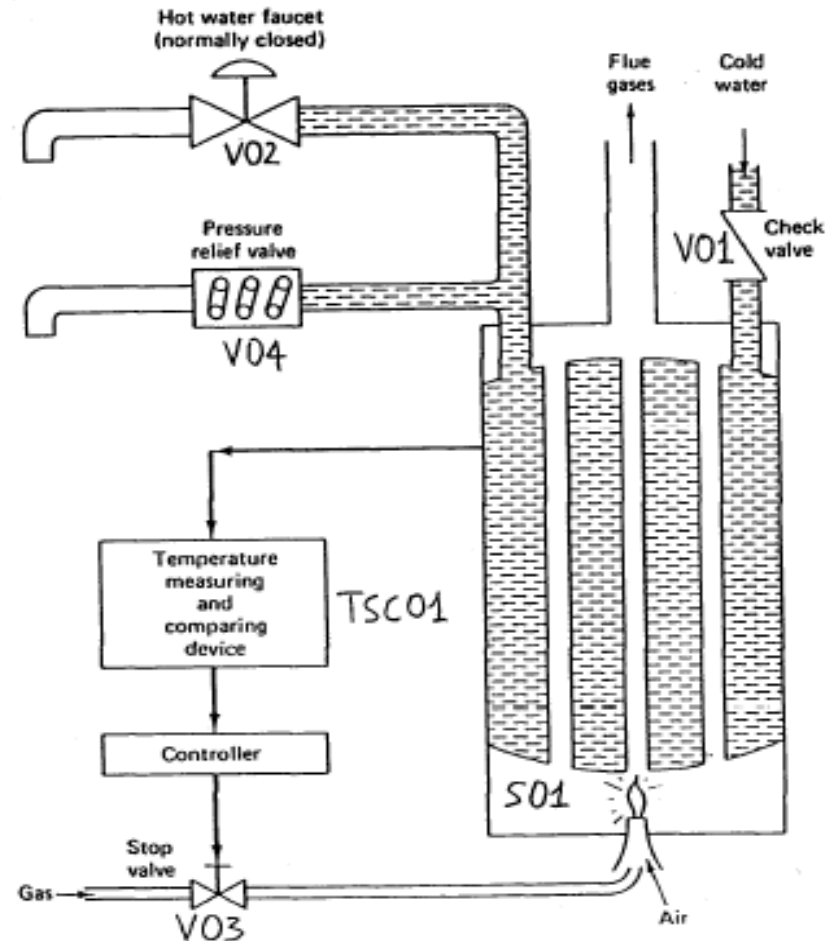



Event Tree Analysis (ETA)



Exercise 1: Reliability Block Diagram (Exercise 3 of FTA)

Consider the Reliability Block Diagram in the Figure.

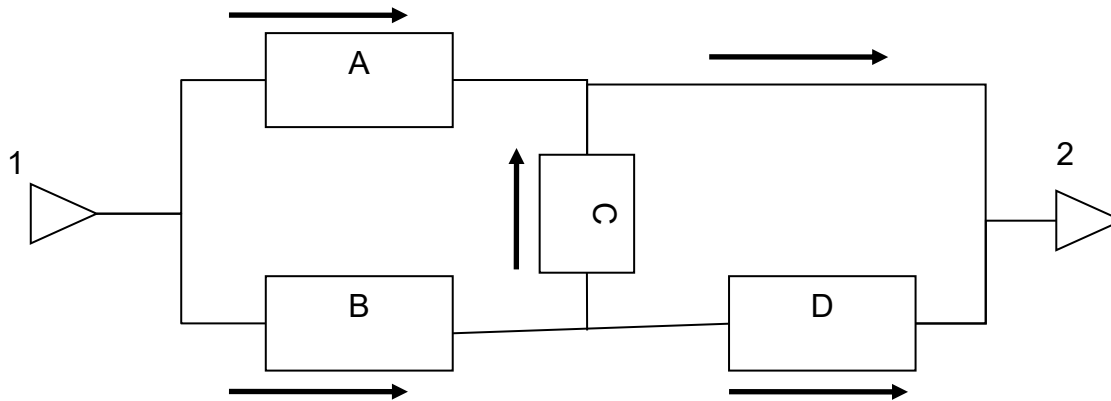

You are asked to:

1. Build the Event Tree with initiating event “loss of flow accident (LOFA)”.
2. Compute the system unavailability from the Event Tree, given that the unavailability of each component is $U=0.01$ and the probability of initiating event is 1. Compare your result with the one obtained in Exercise 3 of FTA.



Exercise 2: Lamp System

The system represented in the figure illustrates the operation of a lamp fed by two batteries and a power unit. In order to have energy in the circuit it is enough that one of the energy sources (i.e., battery 1, battery 2, power unit) works.

Build the event tree for the event “failure of the lighting system” and compute its probability based on the component probabilities indicated on the Figure.

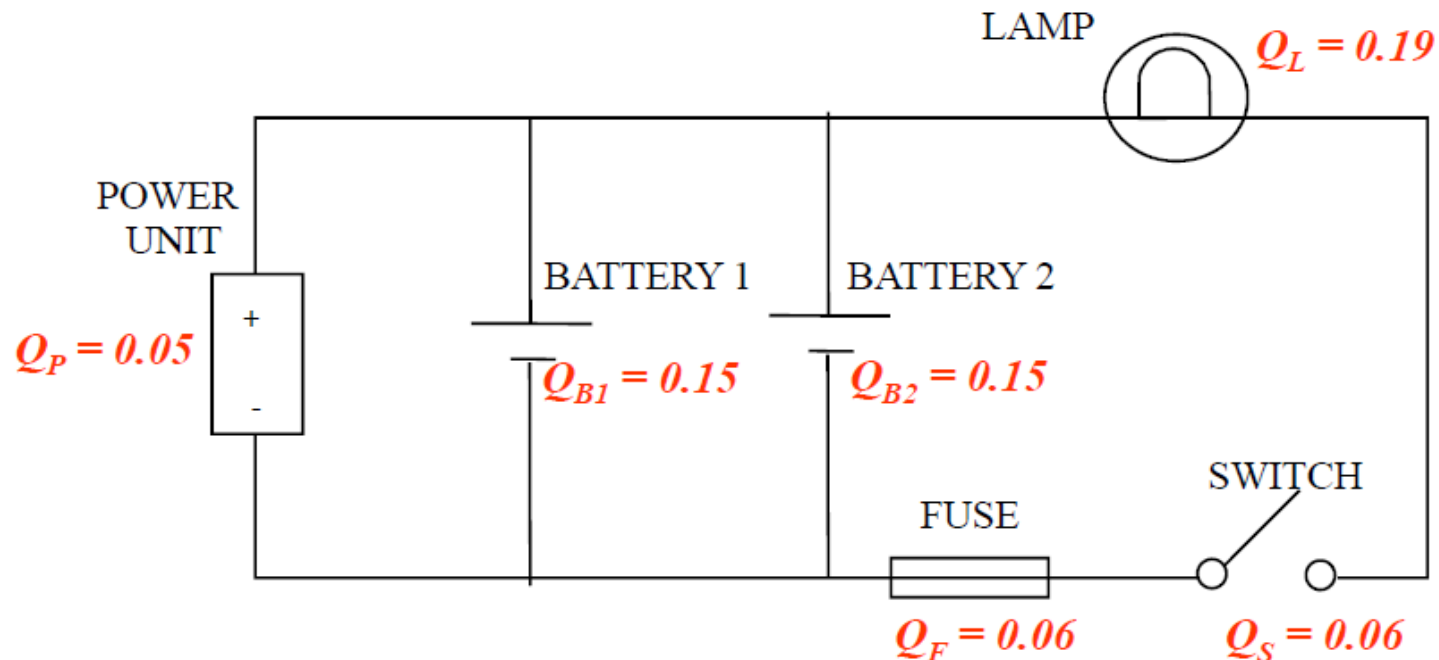



Exercise 3: Gas Release (I)

In a process plant, flammable gas that is accidentally released can be detected by a process operator working in the area.

The process operator can only detect gas if she is present in the area where the gas is released. There are several operators working in the plant, but only one operator is on duty at any time.

If she is not present, she can not detect the gas, but if she is present, there is a possibility that this may happen. **An operator is present 30 % of the time.**

The probability that the operator will not detect the gas is 0.3. If the gas is released, there is a possibility that the release may ignite.

The probability of ignition is 0.1 given that gas is released.

The frequency of gas release is 0.5 per year. If the gas is detected (automatically or by the operator), the operator will try to escape and there is a **50 % probability that she escapes in time if she is present when a gas release takes place.**

Given that someone is in the area when ignition occurs, **the probability of being killed is 0.2.**



Exercise 3: Gas Release (II)

- a) Prepare an event tree with initiating event (top event) “Gas released” and end events “Operator killed” and “Operator not killed” .
- b) What is the frequency of an operator being killed?
- c) What is the LIRA due to gas releases? (LIRA is the annual probability of being killed, given that a person is present in an area for 100% of the time)



Homework Exercise: Electric Grid System

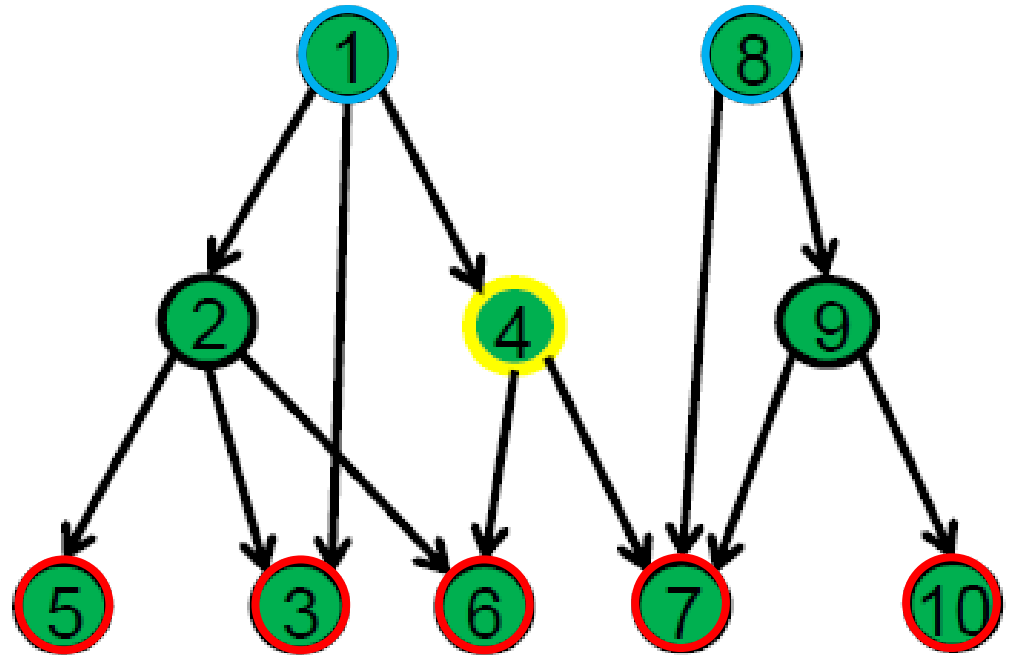
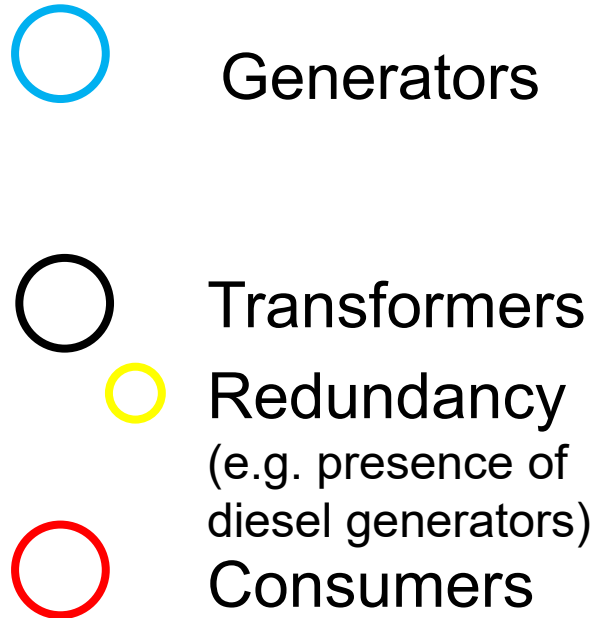

A network with nodes and directed links:

- Each node has two states: **safe vs failed**
- The direction of links indicates the **functional dependency**
- Nodes having redundancy, **yellow circle**, will sustain disruptions coming from upper nodes.
- A node operates when **all the nodes it depends on** are functioning



Homework Exercise: Electric Grid System

Generators in nodes 1 and 8 can be damaged by a landslide, if its magnitude is sufficiently large. The return time of a landslide of such magnitude is 100y.

The failure probability of the generators, conditioned to such landslide occurrence is:

$$P(N1|L) = P(N8|L) = 4 \times 10^{-2}$$

Q1. Draw the Event Tree, with “landslide” as initiating event, and identify the success scenarios “consumers of node 7 are supplied with energy”.

- Consider the **headings** H_k
H1: “Node 8 out of service, due to the landslide”
H2: “Node 1 out of service, due to the landslide”

- Assume the following **conditional probabilities**

$$P(N8|L) = 4 \times 10^{-2}$$

$$P(N1|L) = 4 \times 10^{-2}$$

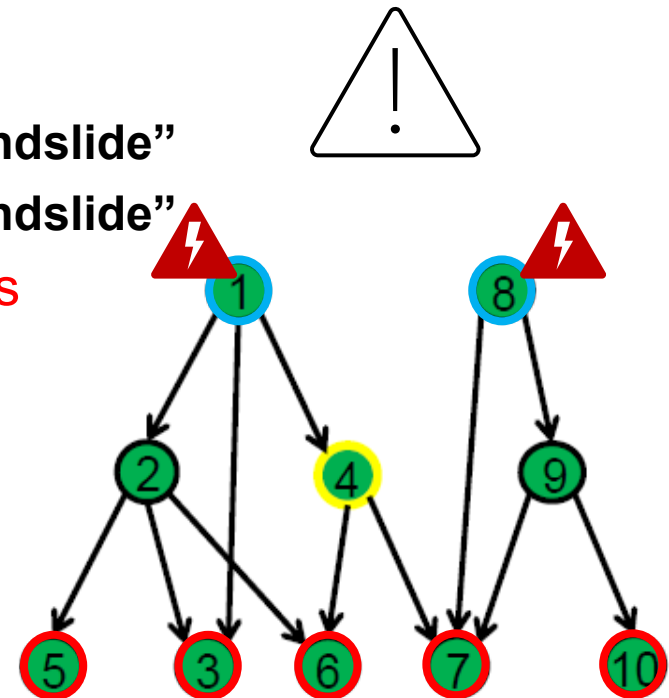



Homework Exercise: Electric Grid System

Generators in nodes 1 and 8 can be damaged by a landslide, if its magnitude is sufficiently large. The return time of a landslide of such magnitude is 100y.

The failure probability of the generators, conditioned to such landslide occurrence is:

$$P(N1|L) = P(N8|L) = 4 \times 10^{-2}$$

Q2. Draw the Event Tree, with “landslide” as initiating event, and identify the success scenarios “consumers of node 7 are supplied with energy”.

- Consider the **headings** H_k

H1: “Node 8 out of service, due to the landslide”

H2: “Node 1 out of service, due to the landslide”

- Assume the following **conditional probabilities**

$$P(N8|L) = 4 \times 10^{-2}$$

$$P(N1|L) = 4 \times 10^{-2}$$

- Consider the hypothesis:

“A node operates when **at least one of the nodes it depends on** is functioning well”

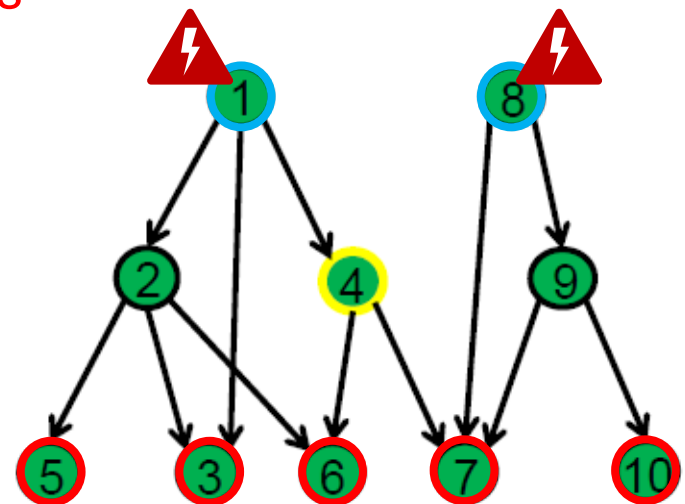



Homework Exercise: Electric Grid System

Generators in nodes 1 and 8 can be damaged by a landslide, if its magnitude is sufficiently large. The return time of a landslide of such magnitude is 100y.

The failure probability of the generators, conditioned to such landslide occurrence is:

$$P(N1|L) = P(N8|L) = 4 \times 10^{-2}$$

Each node (also the redundant ones) is subject to random failures described by exponential distributions with parameter $\lambda = 3 \times 10^{-4} \text{ Y}^{-1}$. Given a mission time of 10 years:

Q3. Draw a Fault Tree and identify the Minimal Cutsets of the top event: “Consumers of node 7 are not supplied with energy”



- Consider the hypothesis:
“A node operates when **all the nodes it depends on** are functioning well”

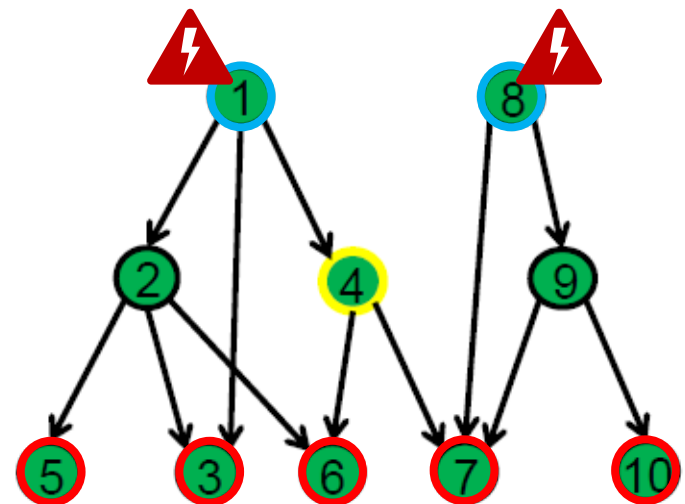



Homework Exercise: Electric Grid System

FT – Hints:

- Define the **top event**:
“Consumers of node 7 are not supplied with energy”
- Decompose the top event by identifying the **subevents** that can cause it:
“Node 9 fails in next 10y”
“Node 7 fails in next 10y”
“Node 4 fails in next 10y”
“Generator 1 fails in next 10y”
“Generator 8 fails in next 10y”
- Decompose each sub-event by identifying more elementary subevents that can cause it until the **basic events** are identified:
- Build the fault tree

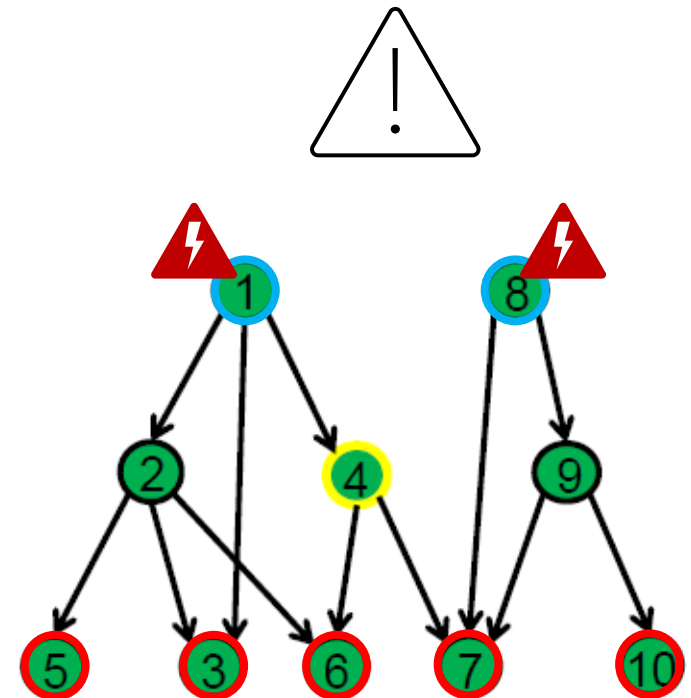



R and Rstudio for Hands-on Exercises on Fault Tree Analysis



Installation of R and RStudio

First install R and then RStudio

- R
 - <http://www.r-project.org/>
- RStudio
 - <http://www.rstudio.org/>

Download A (very) short introduction to R:

<https://cran.r-project.org/doc/contrib/Torfs+Brauer-Short-R-Intro.pdf>



Installation of FT Packages

Download the manual for FaultTree Package:

<https://cran.r-project.org/web/packages/FaultTree/FaultTree.pdf>

Run the command:

```
install.packages("FaultTree")
```

After installing, load the package:

```
library("FaultTree")
```

FaultTree package is ready to be used!



Building a FT using FaultTree Package

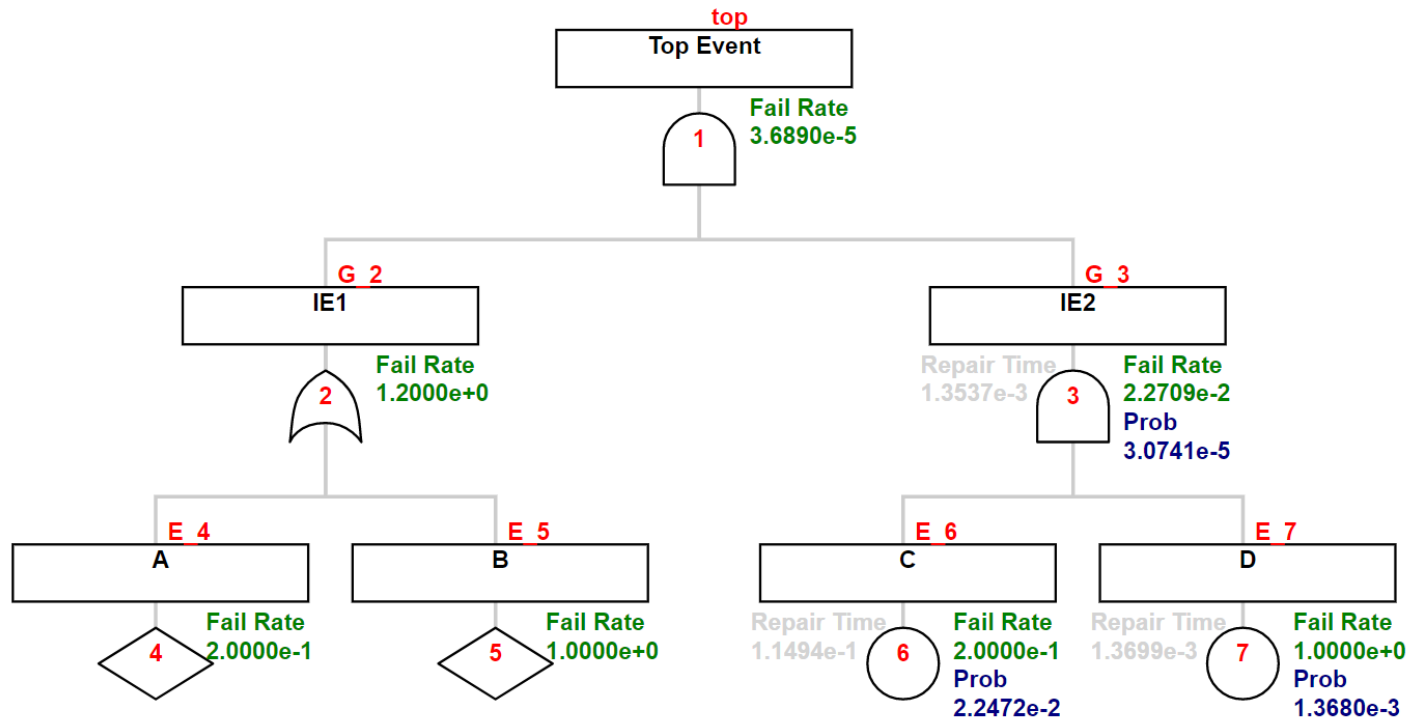



Building a FT using FaultTree Package

```
tree1 <- ftree.make(type="and", name="Top Event")
```

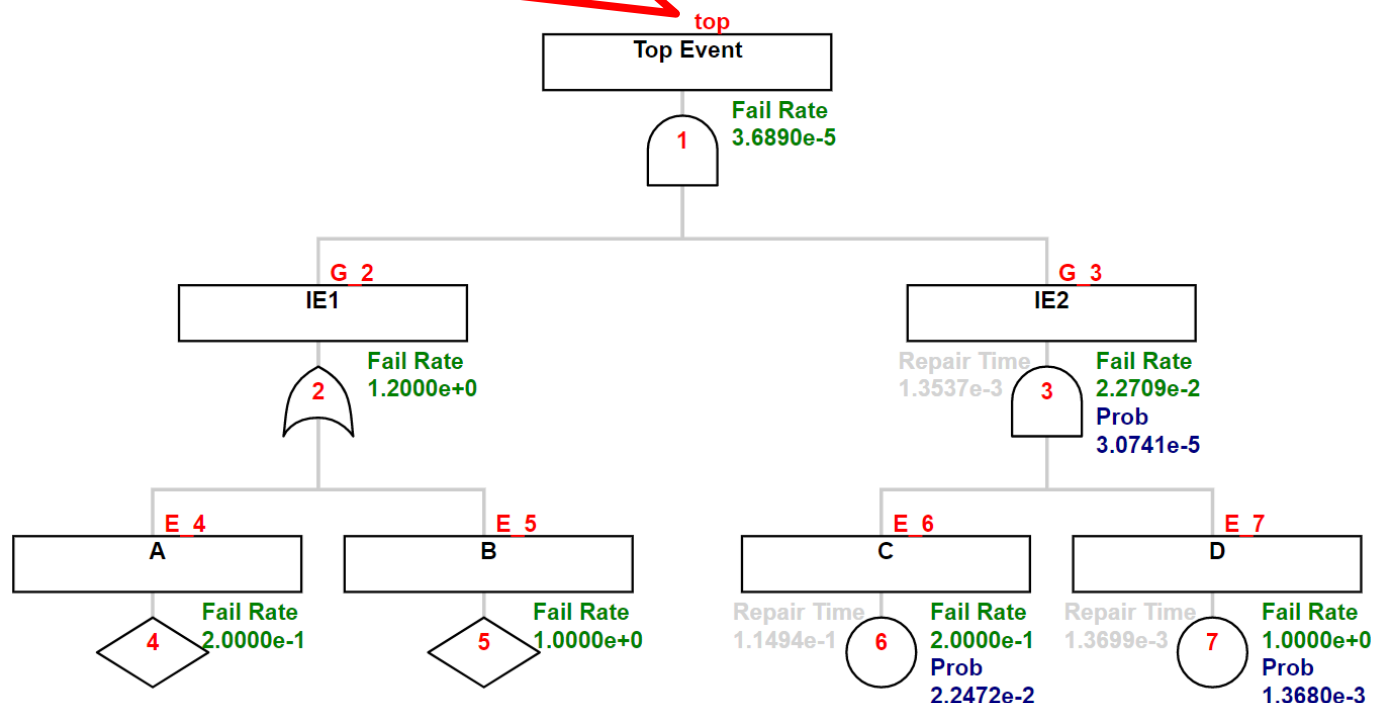



Building a FT using FaultTree Package

```
tree1 <- addLogic(tree1, at=1, type="or", name="IE1")
```

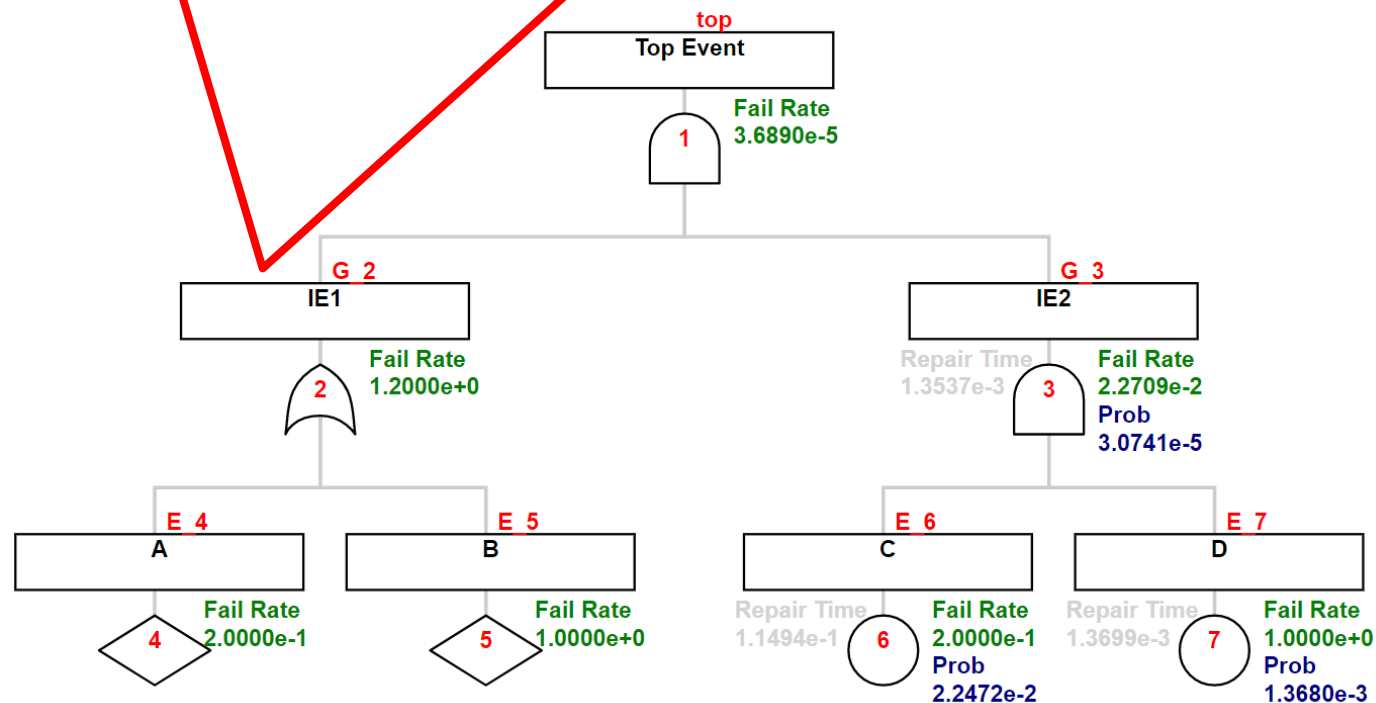



Building a FT using FaultTree Package

```
tree1 <- addLogic(tree1, at=1, type="and", name="IE2")
```

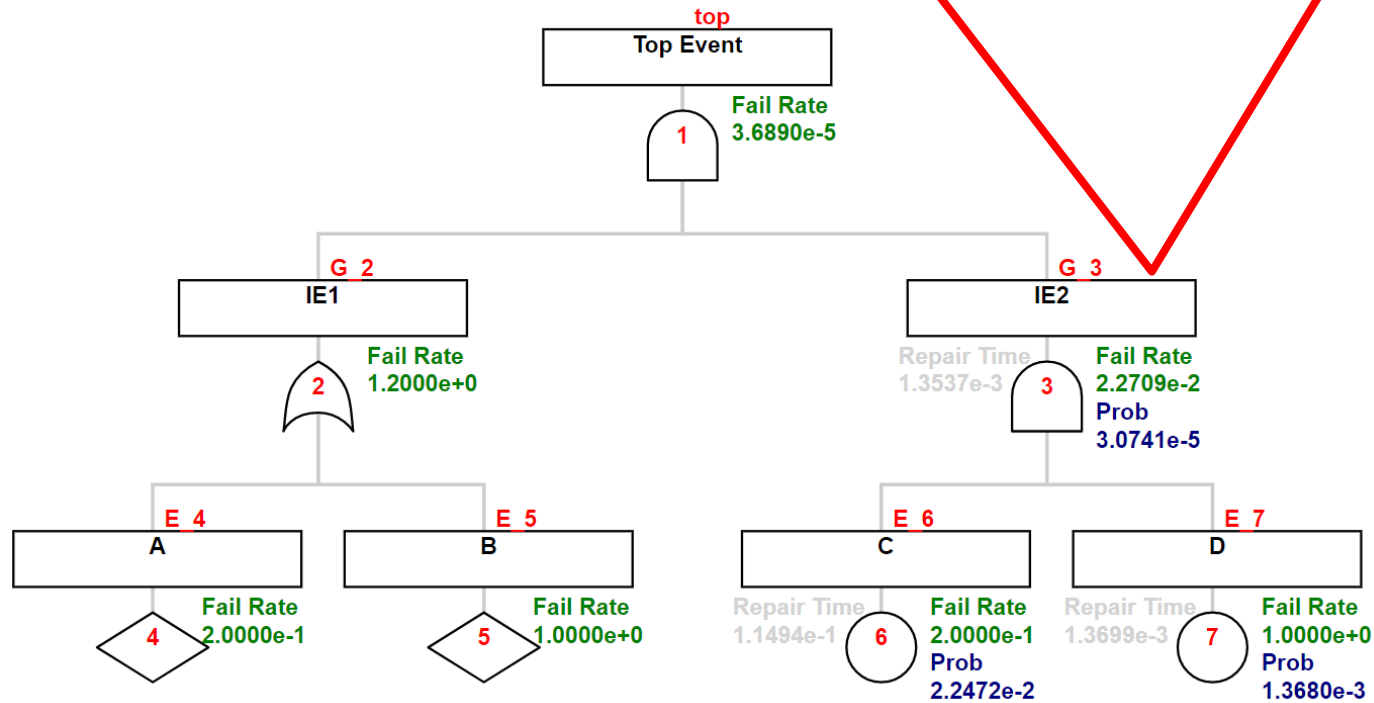



Building a FT using FaultTree Package

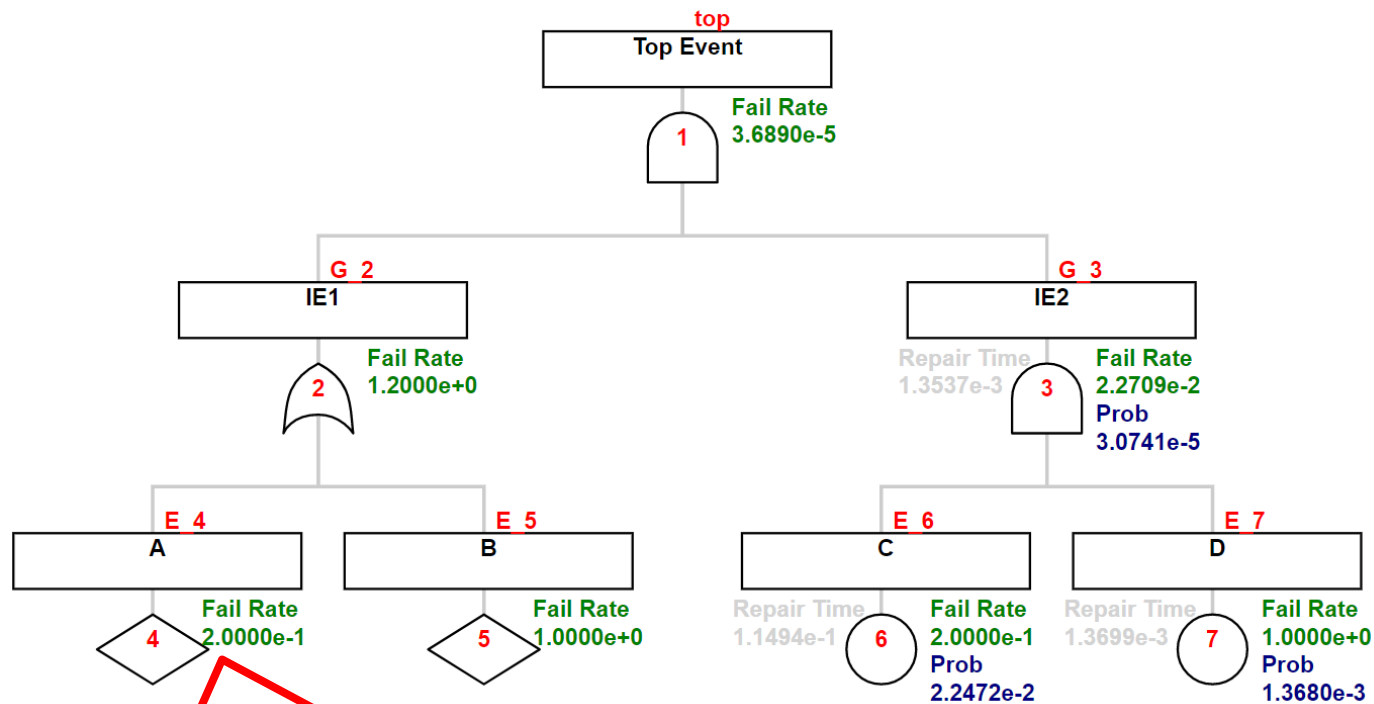

```
tree1 <- addDemand(tree1, at=2, mttf=5, name="A")
```



Building a FT using FaultTree Package

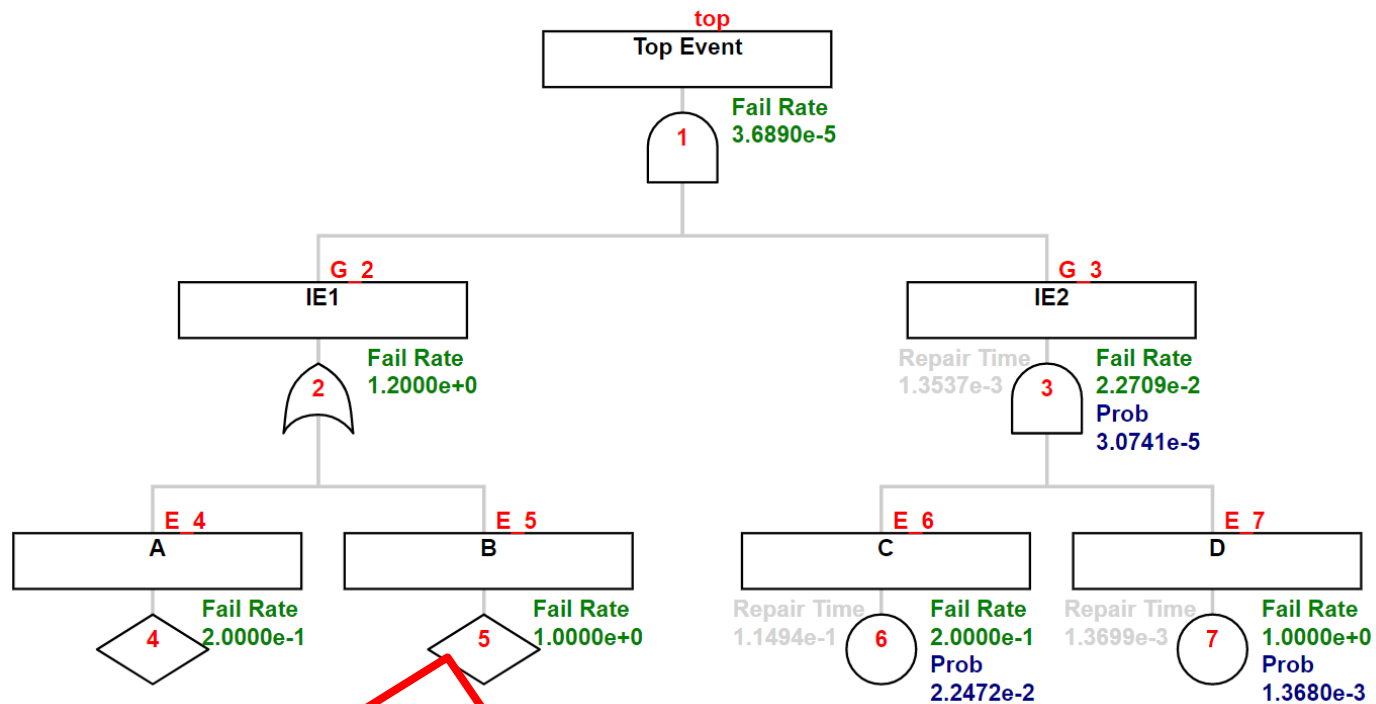

```
tree1 <- addDemand(tree1, at=2, mttf=1, name="B")
```



Building a FT using FaultTree Package

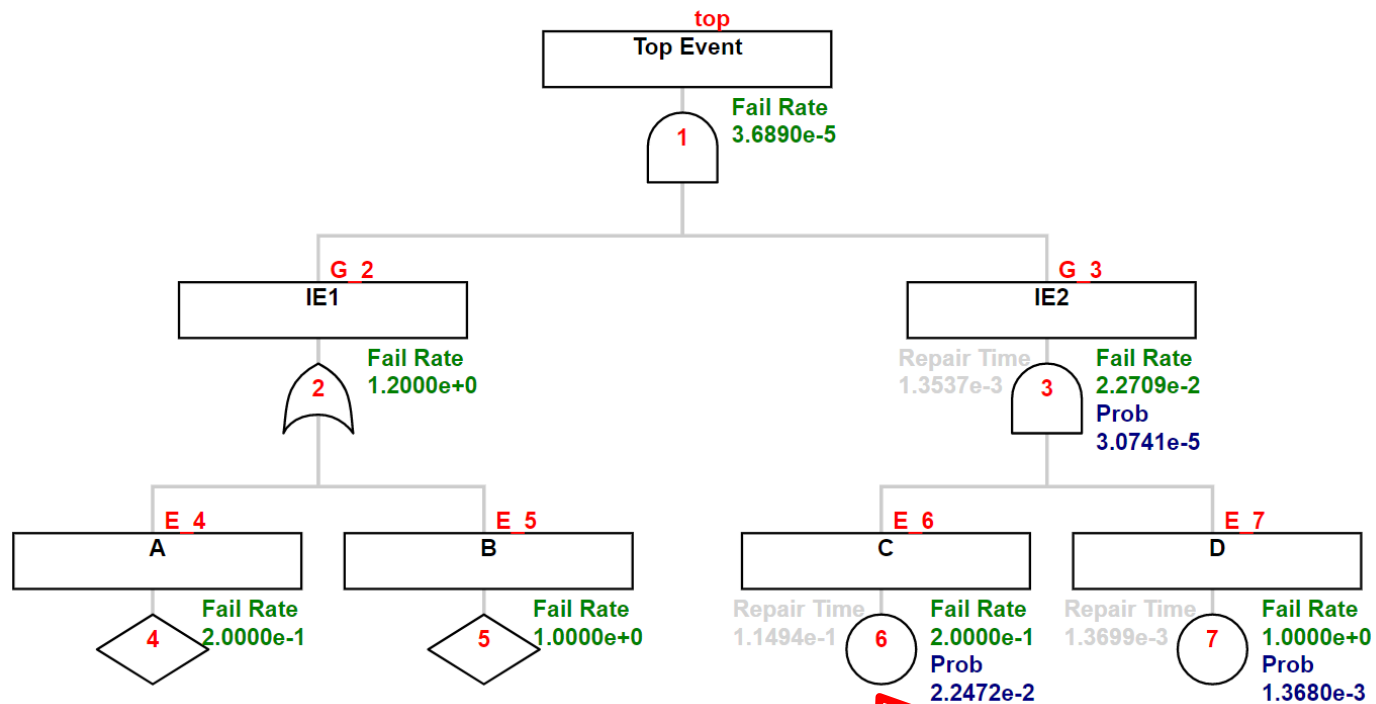

```
tree1 <- addActive(tree1, at=3, mttf=5, mttr=10/87, name="C")
```



Building a FT using FaultTree Package

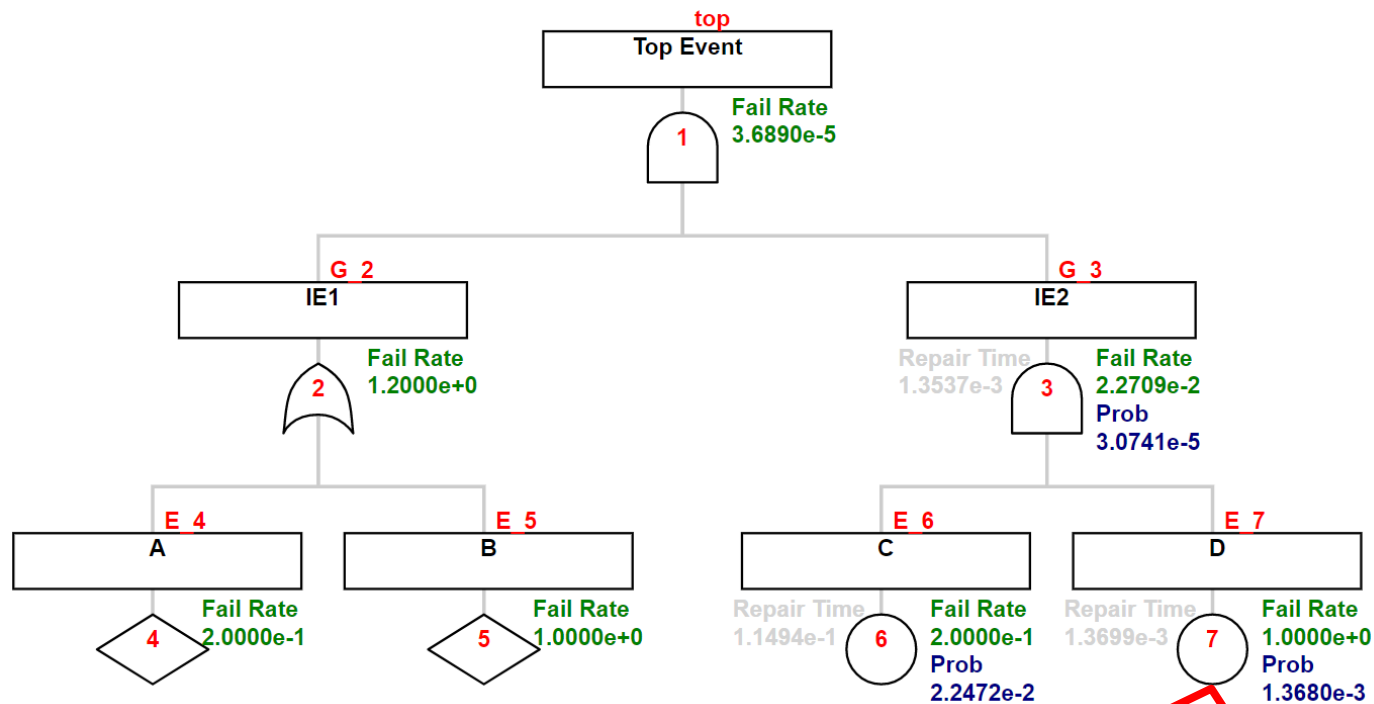

```
tree1 <- addActive(tree1, at=3, mttf=1,mttr=12/8760, name="D")
```



Building a FT using FaultTree Package

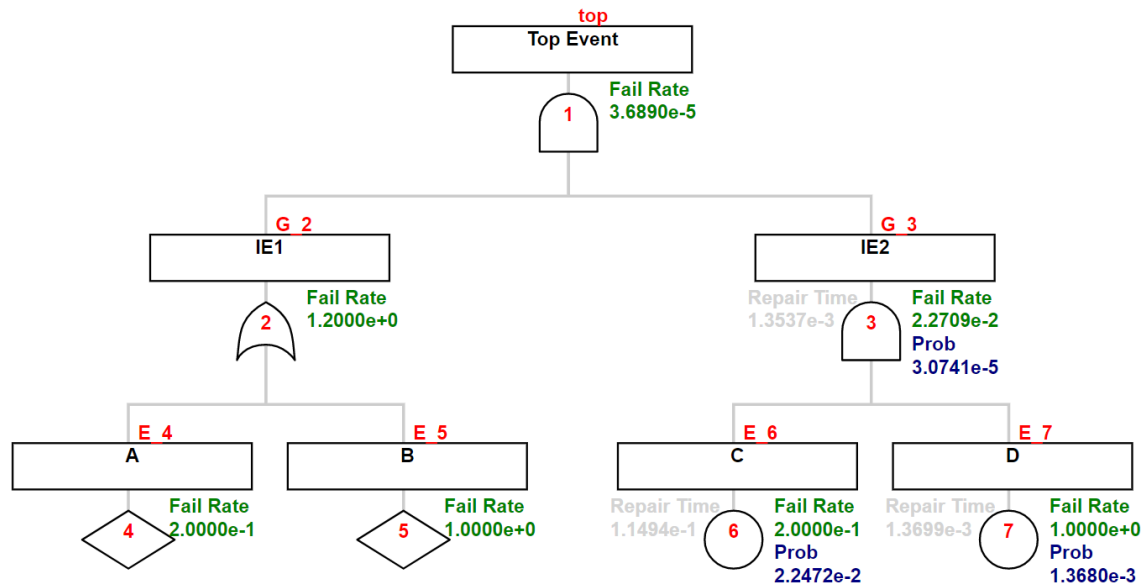

library(FaultTree)

```
tree1 <- ftree.make(type="and", name="Top Event")
tree1 <- addLogic(tree1, at=1, type="or", name="IE1")
tree1 <- addLogic(tree1, at=1, type="and", name="IE2")
tree1 <- addDemand(tree1, at=2, mttf=5, name="A")
tree1 <- addDemand(tree1, at=2, mttf=1, name="B")
tree1 <- addActive(tree1, at=3, mttf=5, mttr=10/87, name="C")
tree1 <- addActive(tree1, at=3, mttf=1, mttr=12/8760, name="D")
```