

Event tree analysis



Prof. Enrico Zio

Politecnico di Milano
Dipartimento di Energia

- **Systematic and quantitative**
- **Inductive**

AIM:

- 1. Identification of possible scenarios (accident sequences), developing from a given accident initiator**
- 2. Computation of accident sequence probability**

ETA: Procedure steps

- 1. Define accident initiator I (system failure);**
- 2. Identify safety/protection systems (S_k) demanded by I**
- 3. Specify failure/success states of S_k**
- 4. Combine the states of all S_k to generate accident sequences**

Event Tree

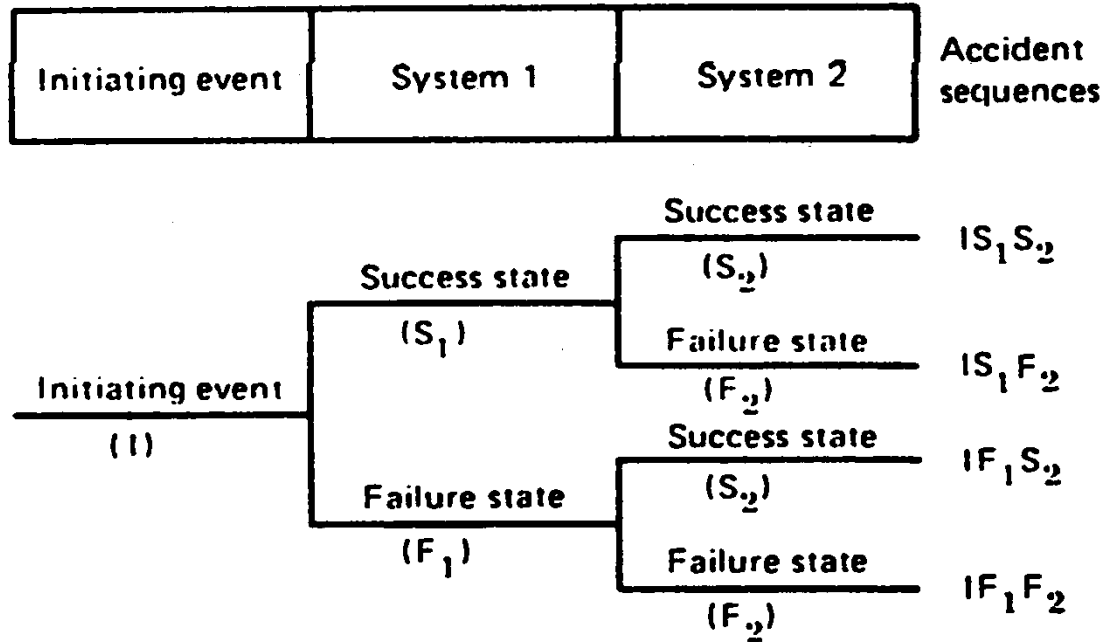

Event Tree Example 1: Fire protection system

Example: *Fire protection system*

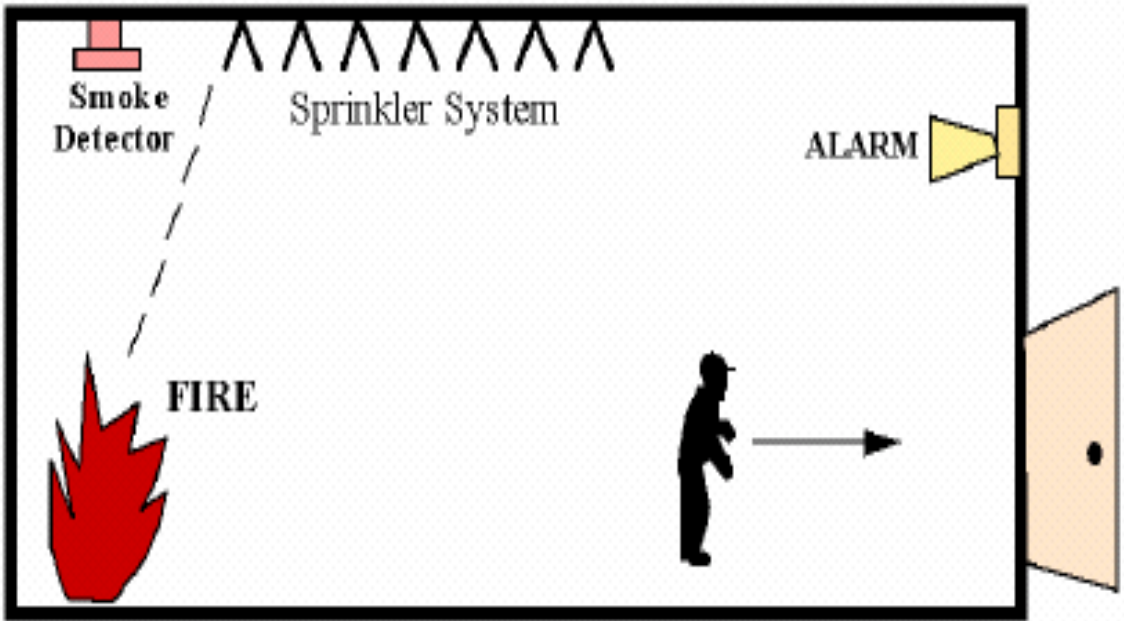

Event Tree Example 2: Release of flammable gas

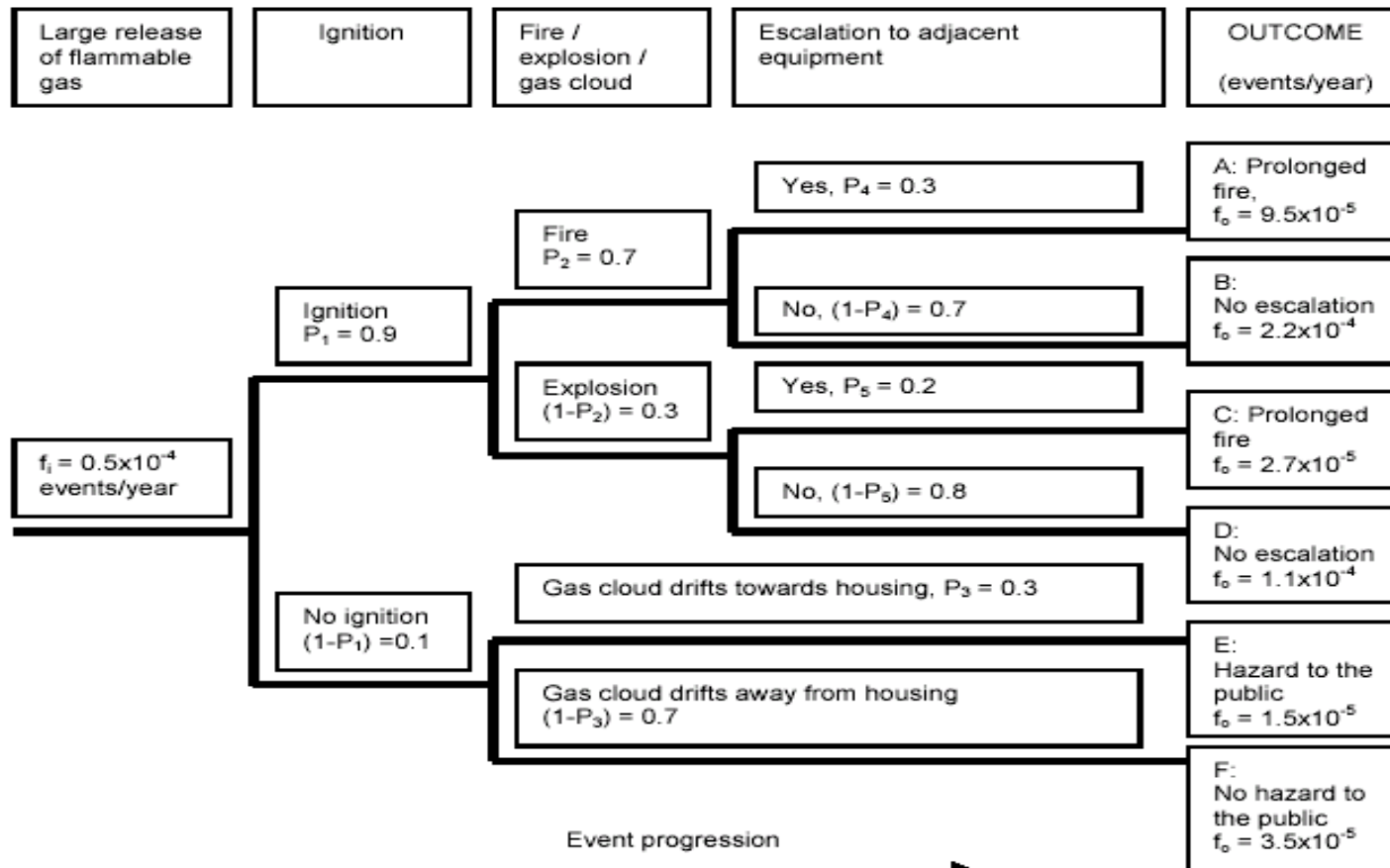

Event Tree Example 3 Loss of coolant accident

Depressurize System

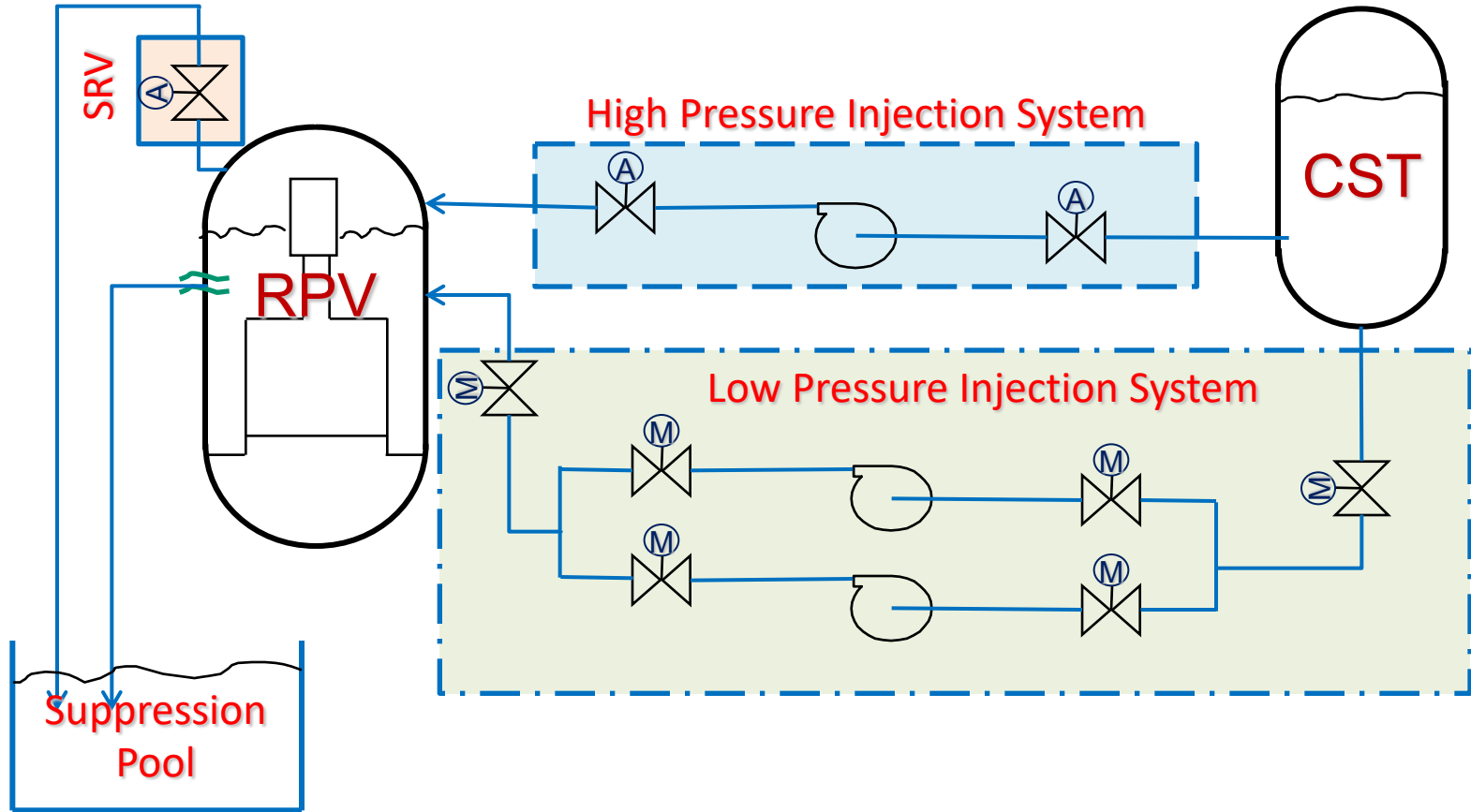

Event Tree Example 3 (cont.)

- A small pipe crack can induce the loss of coolant of the reactor pressure vessel (RPV). The frequency of this event is $5.0E-4$.
- Under the small loss of coolant accident (SLOCA) condition, the RPV water level drops due to the crack and decay heat. When it drops to a certain low level, the high pressure injection system (HPIS) starts to pump water into the core.
- In case that the HPIS works properly, the RPV can be depressurized under control and low pressure injection system (LPIS) will take care of long term heat removal to bring the core to safe status.
- If HPIS fails (at probability of $2.0E-3$), the water level goes down to another setting level and trigger-starts LPIS. Then the operator has to open the safety relief valve (SRV) to relief the RPV pressure in order to keep LPIS pumping the water into the core.
- In case either the operator fails to open SRV (at probability of $5.0E-3$) or LPIS fails (at probability of $5.0E-4$), the core will be damaged.

1. **One ET for each accident initiator**
2. **Time and logic of S_k interventions important for the tree structure (simplifications possible)**
3. **S_k states conditional on accident initiator and previous S_j 's**
4. **Conditional probabilities of S_k states (FTA)**

ETA+FTA

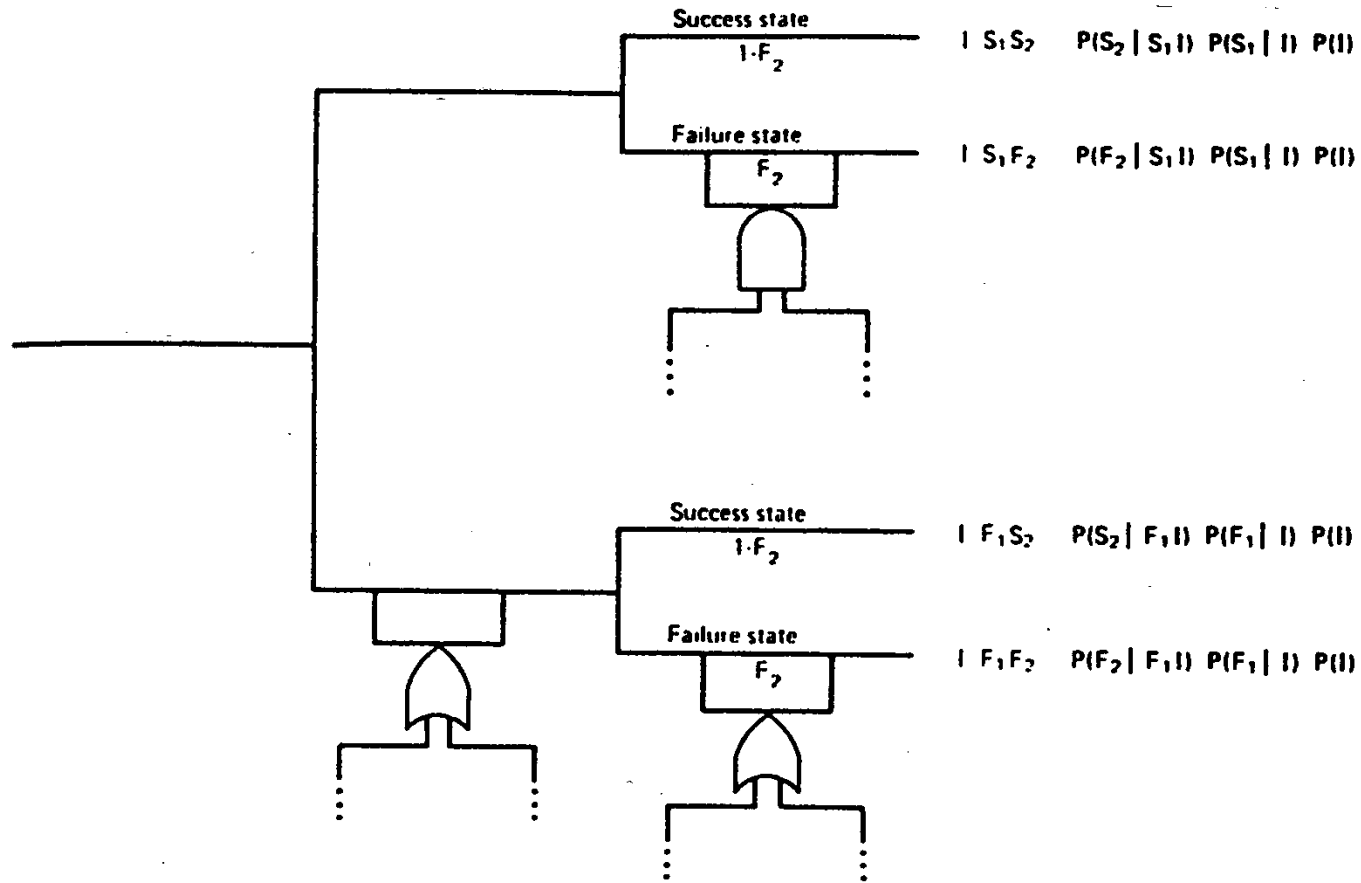

Event Tree Analysis

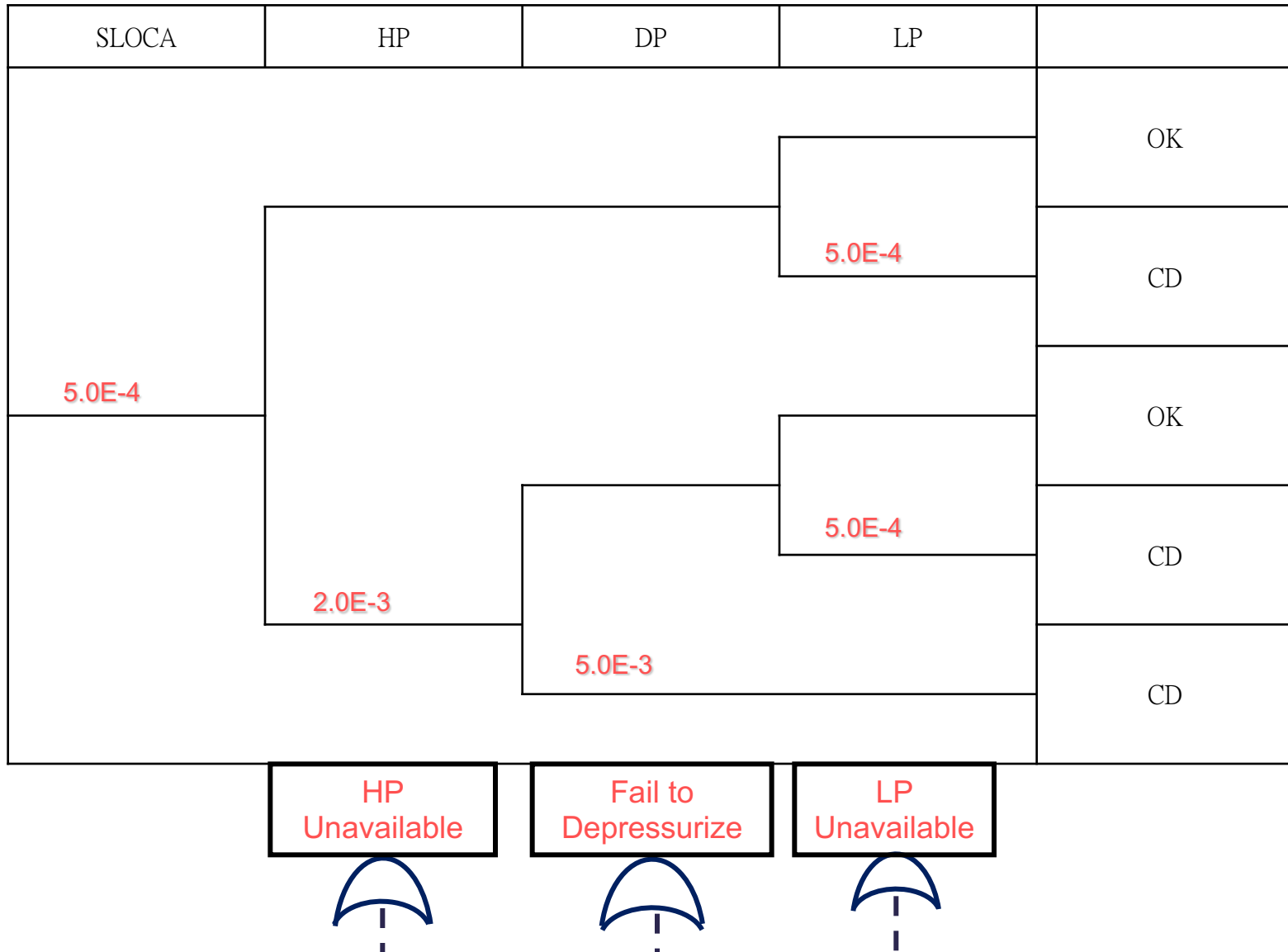

Event Tree Example 3 Loss of coolant accident

Depressurize System

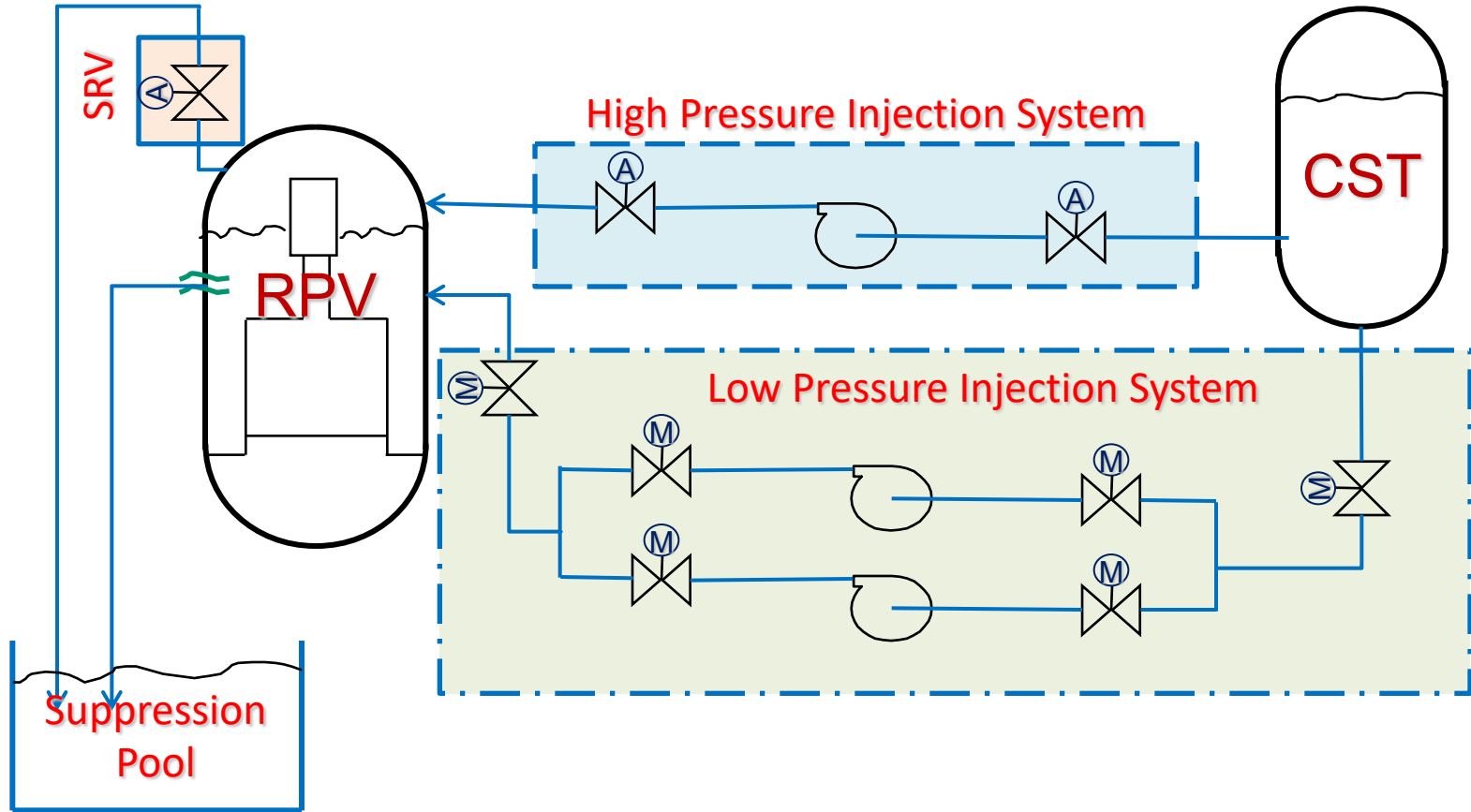

MONTE CARLO SIMULATION

- Perform many simulations (trials or histories) of the system life during its mission time
- Each trial is a random walk of the system from one stochastic configuration to another, at stochastic times.
- For each piece of walk, starting from a given system configuration k' entered at t' , we need to determine when the next transition occurs and which new configuration is reached by the system.
- When the system enters in a failure configuration, we record the event realization
- Perform statistical estimates on the failure events to compute system failure probabilities

MONTE CARLO SIMULATION

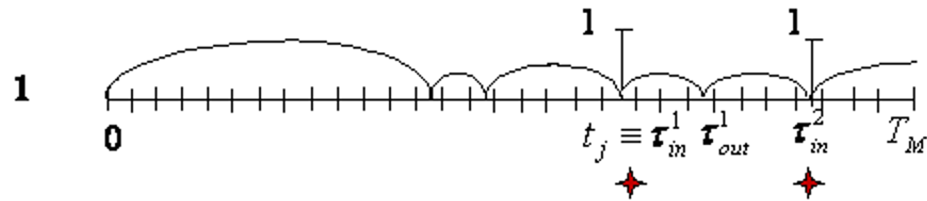

$$c^R(t_j) = c^R(t_j) + 1$$

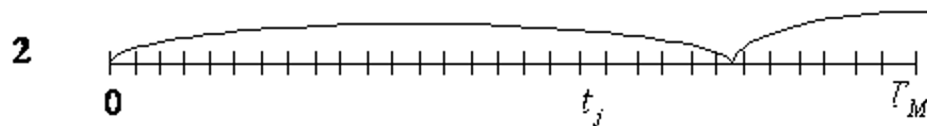

$$c^R(t_j) = c^R(t_j)$$

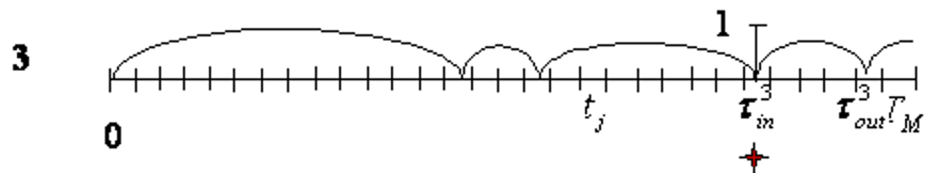

$$c^R(t_j) = c^R(t_j)$$

⋮

⋮

⋮

⋮

⋮

$$G^R(t_j) = \frac{c^R(t_j)}{M}$$

